

DUPLEX UNIT

1. REPLACEMENT AND ADJUSTMENT

1.1 COVERS AND PAPER GUIDES

1.1.1 RIGHT SIDE COVER LOW

⚠ CAUTION

It is normally necessary to remove the duplex unit from the printer when servicing the duplex unit. The duplex unit is heavy. Take care not to injure yourself by dropping the duplex unit when removing and installing it.

1. Right Side Cover Low [A] (⚙ x 2).

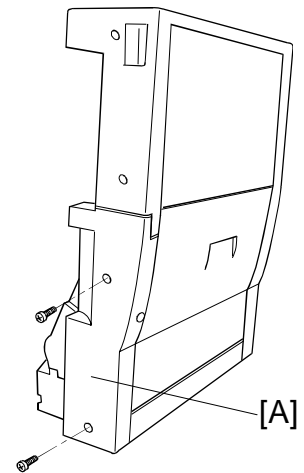

G657R520.WMF

1.1.2 LEFT SIDE COVER LOW

1. Left Side Cover Low [A] (⚙ x 2).

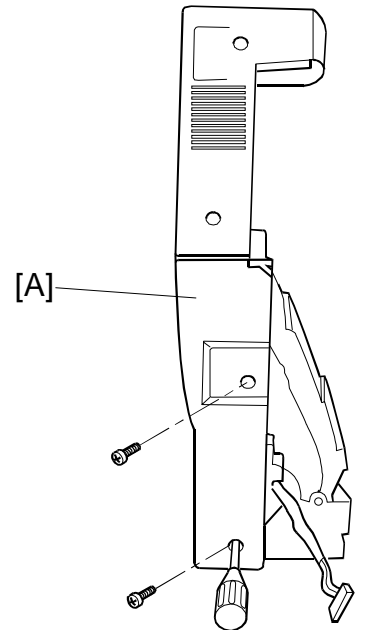

G657R521.WMF

Peripherals

1.1.3 RIGHT COVER TOP

1. Right Cover Top [A] (🔩 x 2).

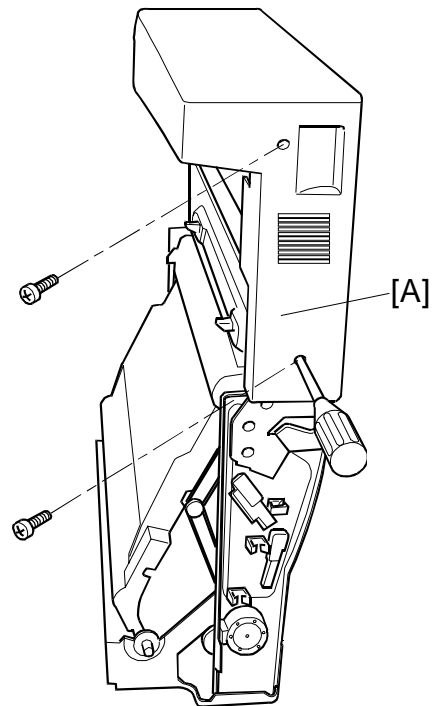

1.1.4 LEFT COVER TOP

1. Left Side Cover Low (☛ 1.1.2).
2. Left Cover Top [B] (2 hooks, 1 clamp).

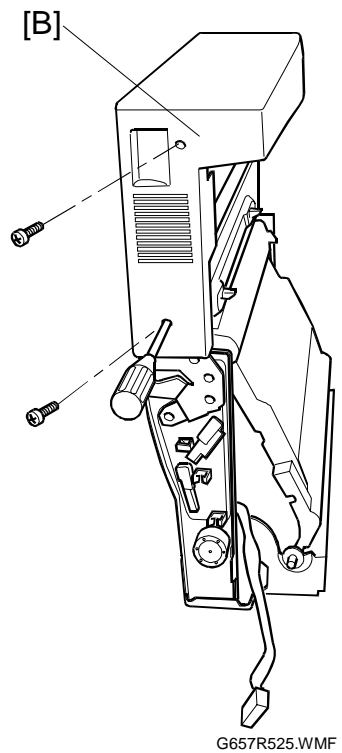

1.1.5 COVER TOP ASSY 1 (WITH 4 GUIDE ROLLERS)

1. Right Side Cover Low (☛ 1.1.1).
2. Right Cover Top (☛ 1.1.3)
3. Duct [A] (☛ x 2).
4. Open the Duplex Top Cover Unit [B].
5. Cover Top Ass'y 1 [C] (☛ x 4, 3 hooks), from the upper unit [D].

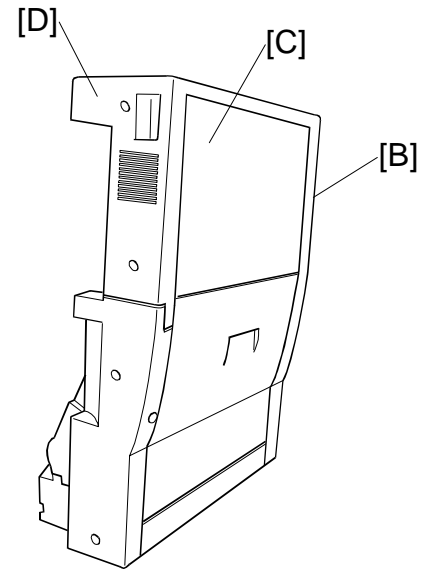

G657R501.WMF

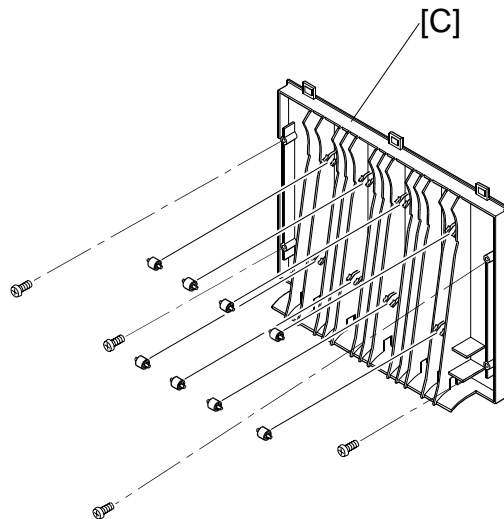

G657R526.WMF

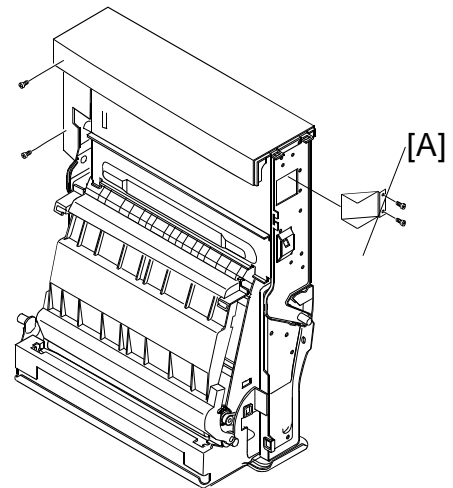

G657R527.WMF

Peripherals

1.1.6 COVER TOP ASSY 2 (WITH 4 GUIDE ROLLERS)

1. Right Side Cover Low, Left Side Cover Lows, Right Cover Top, Left Cover Top (☛ 1.1.1 through 1.1.4)
2. Fan Motor (🔩 x 4).
3. Cover Top Ass'y 2 [A] (🔩 x 4).

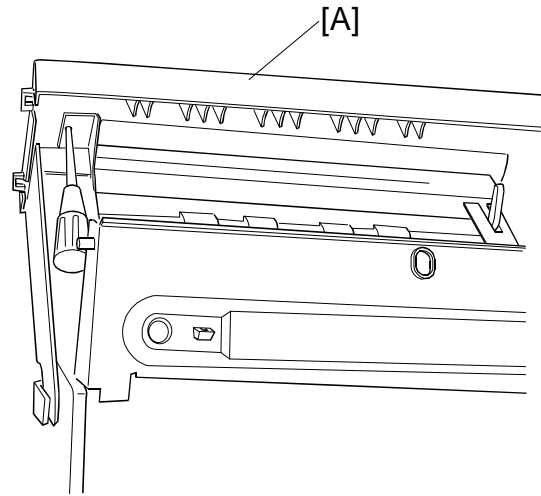

G657R502.WMF

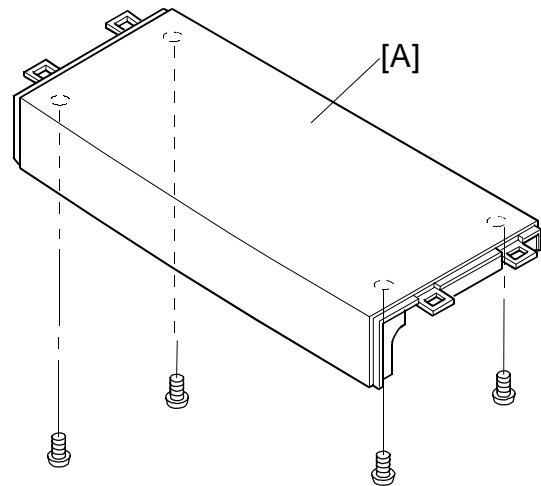

G657R528.WMF

1.1.7 COVER LOW ASSY (INCLUDING 4 GUIDE ROLLERS, HANDLE, AND LOCK LEVER)

1. Open the Cover Low [A].
2. Cover Low Ass'y [A] (⌀ x 4), from the hinge metal fixture [B].

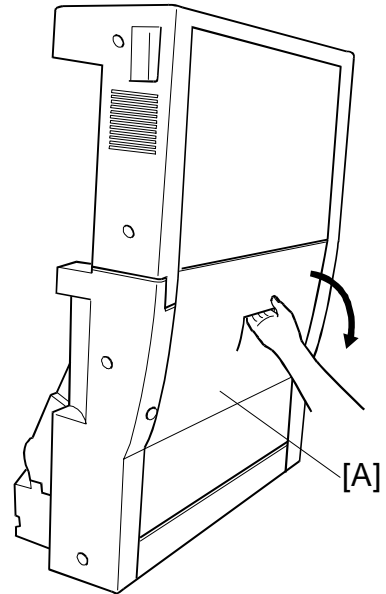

G657R516.WMF

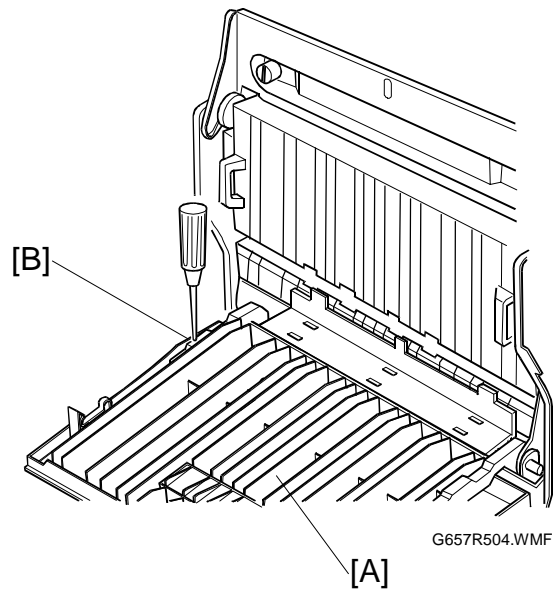

G657R504.WMF

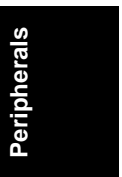

1.1.8 BOTTOM COVER ASS'Y

1. Separate the D-Lower unit from the D-Top unit (☛ 1.2)
2. Cover Low Ass'y [A] (☛ 1.1.7)
3. Harness cover [B].
4. Screws [C] (M4 x 6, 2 pcs), from the bottom cover.
5. Harness inside the bottom cover.
6. Paper guide RVS unit (☛ 1.1.9).
7. Bottom cover [D], from the base.

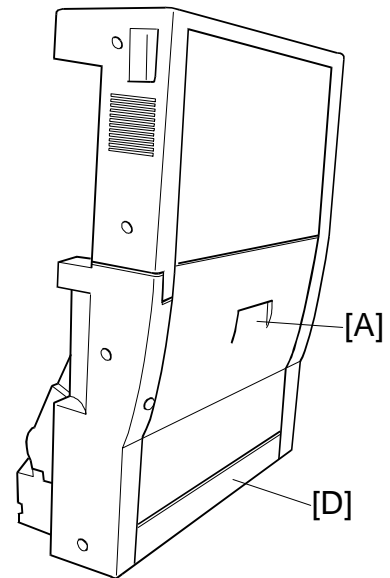

G657R501.WMF

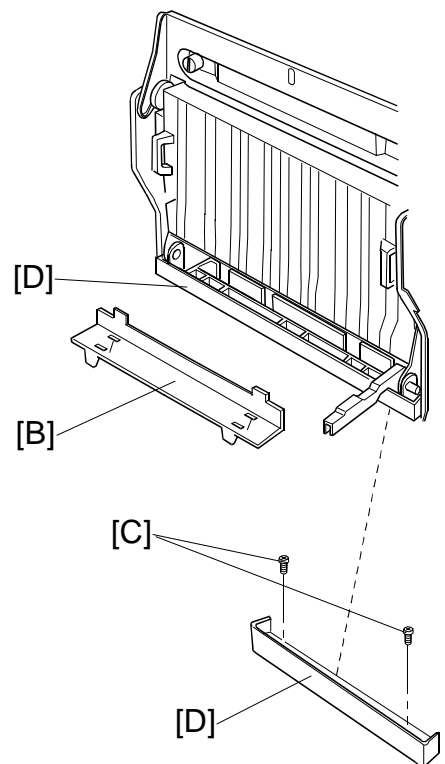

G657R503.WMF

1.1.9 PAPER GUIDE RVS UNIT

1. Right Cover Low and Left Cover Low. (☛ 1.1.1 and 1.1.2)
2. Paper Guide RVS IN. (☛ 1.1.10)
3. Screws (M3 x 5, 4 pcs.) from the support shaft at both sides (left & right). After this, the Cover Low Assy [A]. comes off (☛ 1.1.7)
4. Support shaft, from the frame.
5. Retaining band [B], from the Paper Guide RVS Unit [C].
6. Paper guide bottom (☛ 1.1.11)
7. Harness connected to connector CN2 on the Relay board.
8. Paper guide RVS Unit [C], from the frame.

NOTE: When putting back the Paper Guide RVS unit and Paper Guide RVS IN, pass the retaining band [B] through the shaft [D].

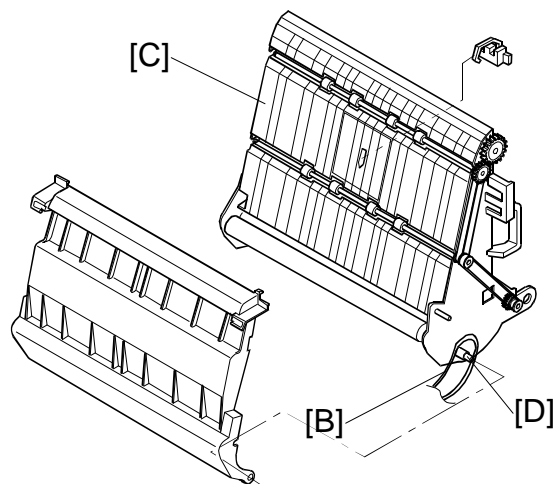
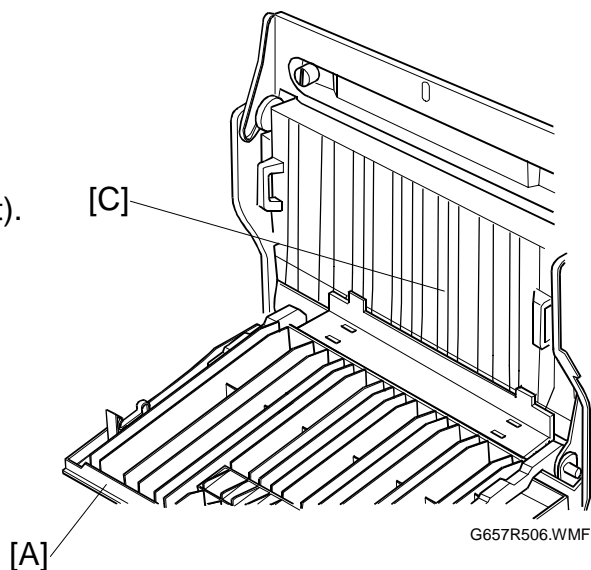

1.1.10 PAPER GUIDE RVS IN

1. Open the Cover Low [A].
2. Open the Paper Guide RVS Unit [B].
3. Flex the hinge arms [C] of Paper Guide RVS IN slightly away from the shaft.
4. Paper Guide RVS IN [D].

NOTE: When putting back the Paper Guide RVS IN [D], pass the retaining band [E] through the shaft [F].

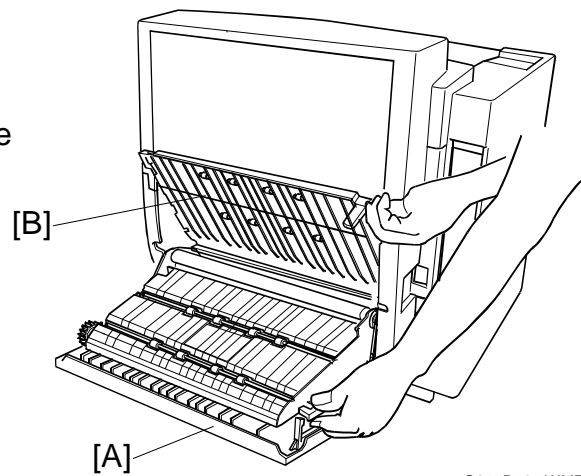

G657R505.WMF

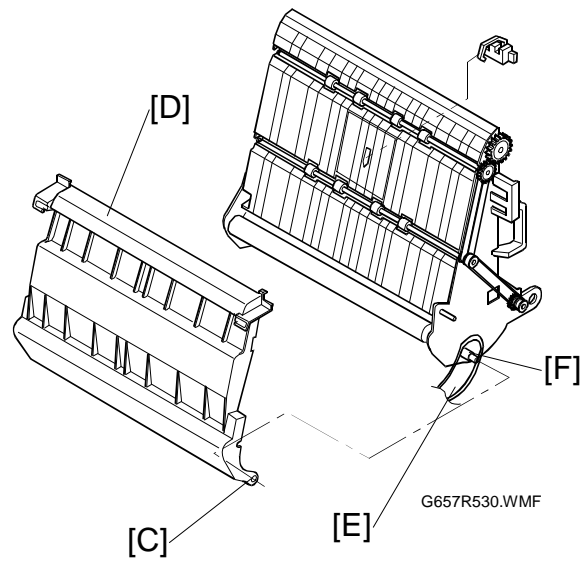

G657R530.WMF

1.1.11 PAPER GUIDE BOTTOM

1. Open the Cover Low.
2. Open the Paper Guide RVS Unit [A].
3. Paper Guide Bottom [B] ( x 1, 4 hooks, connector x 1).

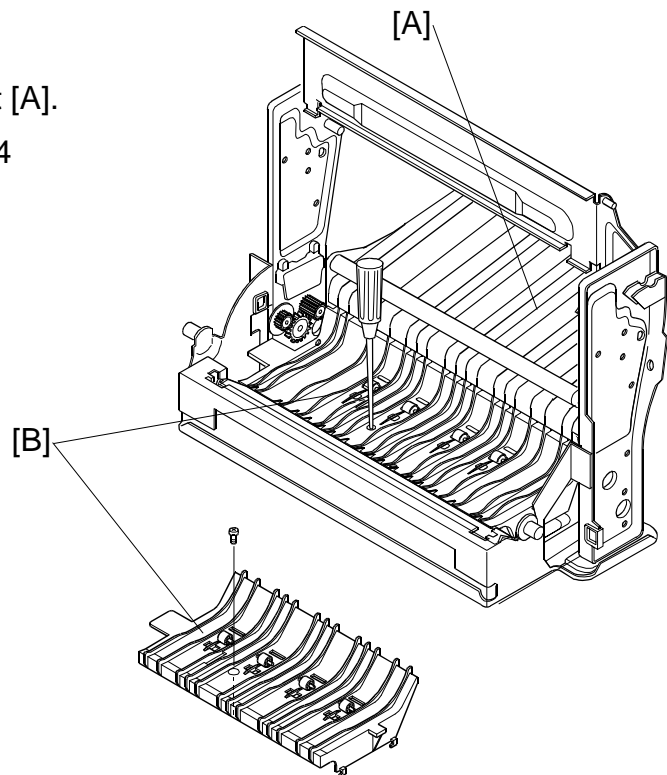

G657R531.WMF

1.2 PAPER TOP ASSY

1.2.1 SEPARATION OF D TOP UNIT AND D LOWER UNIT

1. Right Cover Low, Left Cover Low. (☛ 1.1.1 and 1.1.2)
2. Disconnect the solenoid, and remove the cable from the clamp.
3. Disconnect the fan, and remove the cable from the clamp.
4. Remove the screws [A] from the support pins at both sides (M4 x 8, 1 each at left and right).
5. Open the D-Top Unit [B] and separate the D Top Unit and D Lower Unit [C].

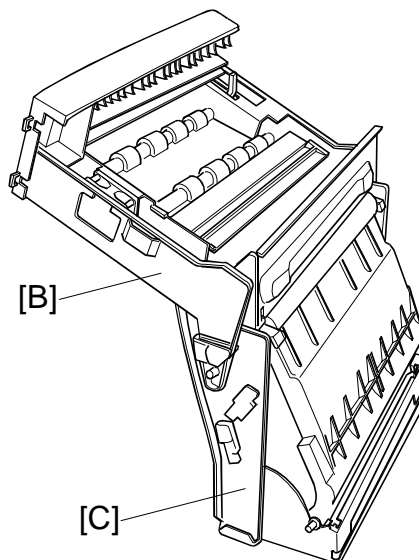

G657R511.WMF

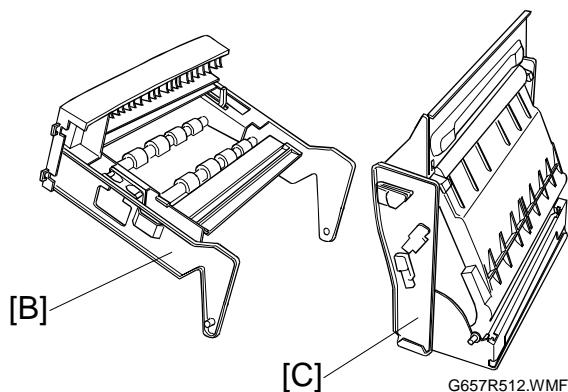

G657R512.WMF

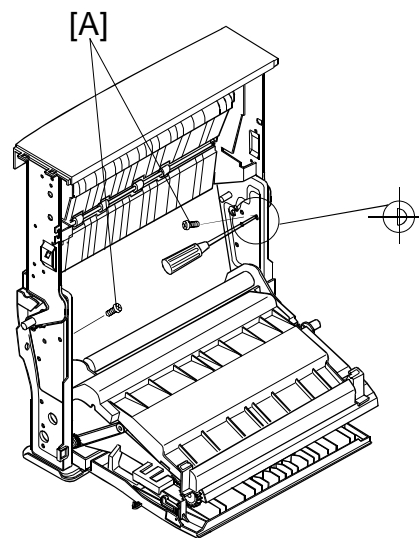

G657R529.WMF

1.2.2 PAPER GUIDE TOP ASSY

1. Right Cover Top and Left Cover Top from the D-Top Unit. (☛ 1.1.3 and 1.1.4)
2. Cover Top 1 from the D-top unit. (☛ 1.1.5)
3. Cover Top 2 from the D-top unit. (☛ 1.1.6)

1.3 PCB

1.3.1 DUPLEX UNIT CONTROLLER BOARD

1. Paper Guide Bottom [A]. (☛ 1.1.11)
2. Duplex unit controller board [B] (⚙ x 4, 1 connector).

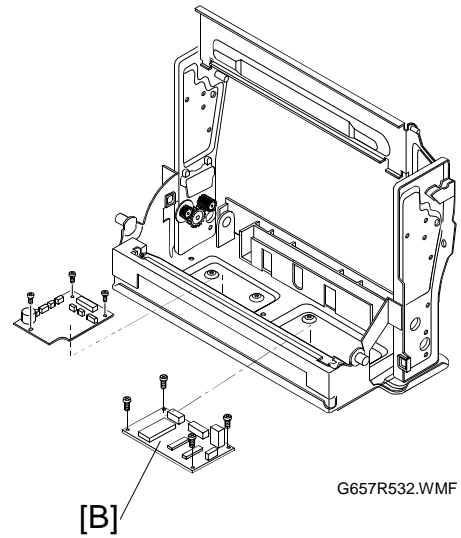
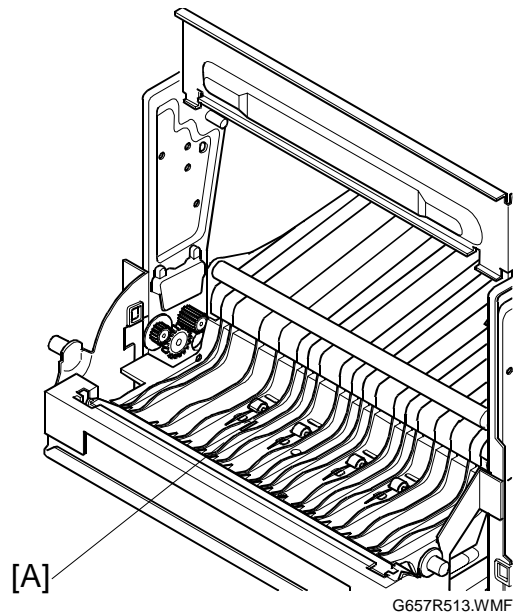

Peripherals

1.3.2 RELAY BOARD

1. Paper Guide Bottom [A]. (☛ 1.1.11)
2. Disconnect all the connectors connected to the Relay board [B].
3. Relay board [B] (⚙ x 3).

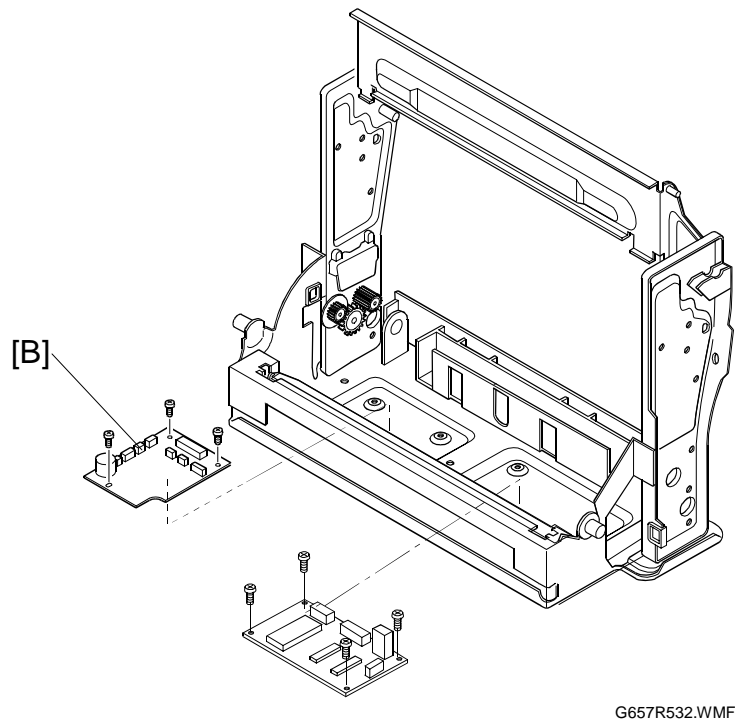
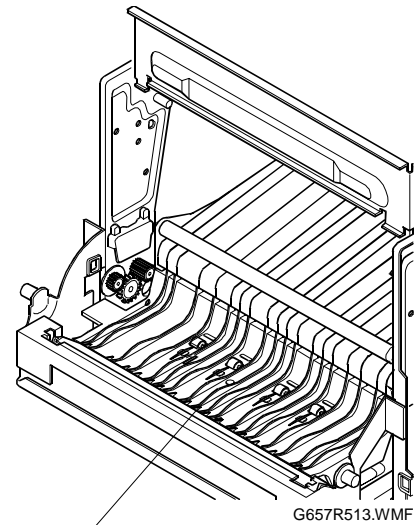

1.4 MOTORS

1.4.1 MOTOR (1)

1. Paper Guide Bottom (☛ 1.1.11) and the Right Side Cover Low (☛ 1.1.1)
2. Disconnect the motor cable from the Relay board CN5.
3. Remove the cable from the clamp.
4. Remove the protective cover (3 hooks).
5. Motor (1) [A] (☛ x 2), from the frame.

NOTE: The motor cable must not contact the gear.

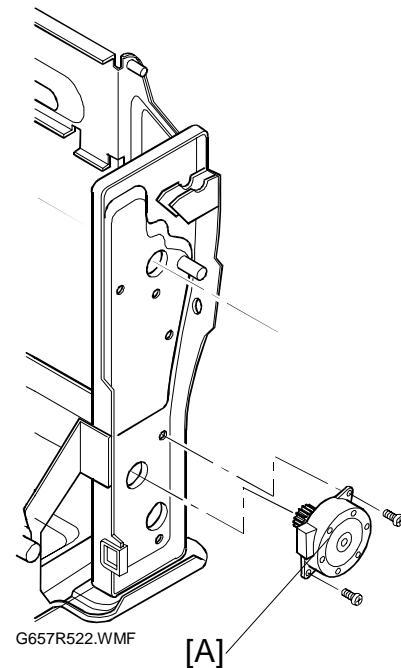

1.4.2 MOTOR (2)

1. Paper Guide Bottom [A] (☛ 1.1.11) and Left Side Cover Low (☛ 1.1.2).
2. Disconnect the motor cable from the Relay board CN7.
3. Harness Cover, and remove the cable from the clamp.
4. Protective cover [B] (3 hooks).
5. Belt, from the motor shaft [C].
6. Motor (2) [D] (⚙ x 2) from the frame.

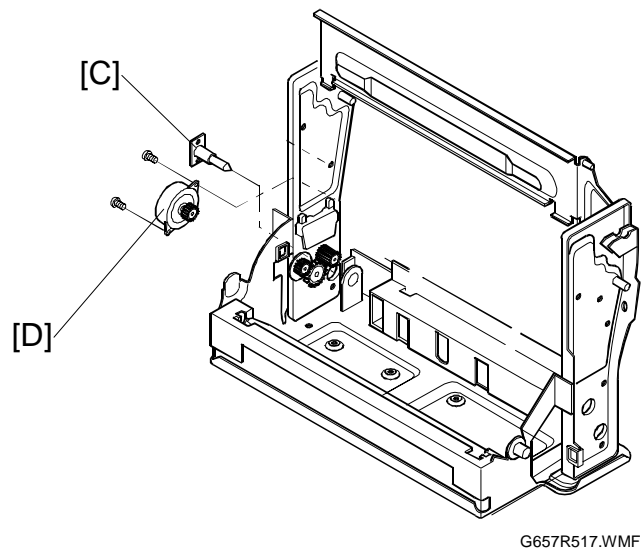
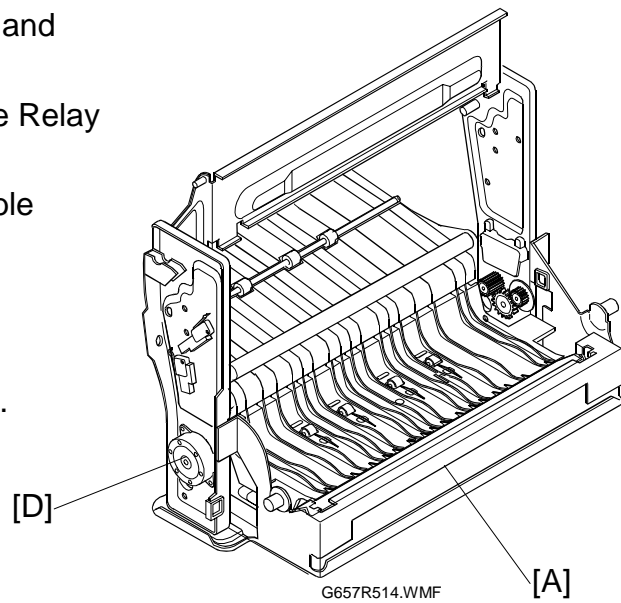

1.4.3 FAN MOTOR

1. Left Side Cover Low. (☛1.1.2)
2. Left Cover Top. (☛ 1.1.4)
3. Disconnect the fan cable [A].
4. Remove the harness from the clamp.
5. Fan motor [B] (M4 x 30,  x 20) from the frame.

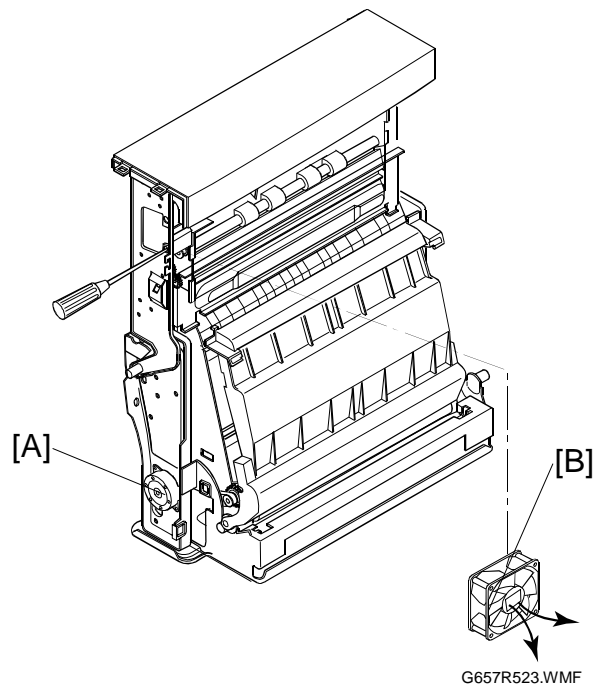

1.5 SOLENOID ASSEMBLIES

1.5.1 UPPER SOLENOID ASS'Y

1. Right Side Cover Low (☛ 1.1.1).
2. Right Cover Top (☛ 1.1.3).
3. Ventilation Duct [A] (☛ x 2).
4. Disconnect the solenoid cable.
5. Remove the cable [B] from the clamp.
6. Upper Solenoid Ass'y [C] (☛ x 2).

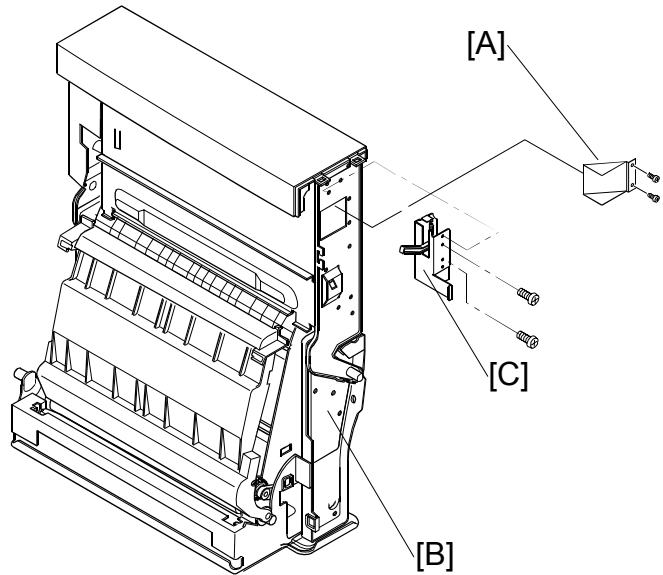

G657R515.WMF

1.5.2 LOWER SOLENOID ASS'Y

1. Paper Guide Bottom. (☛ 1.1.11)
2. Harness Cover.
3. Disconnect the Solenoid (L) cable from the Relay board [A] at CN3
4. Remove the cable from the clamp.
5. Lower Solenoid Ass'y [B] (☛ x 1).

NOTE: When attaching the Lower Solenoid, put the actuator in the lever hole in the Lower Junction Gate.

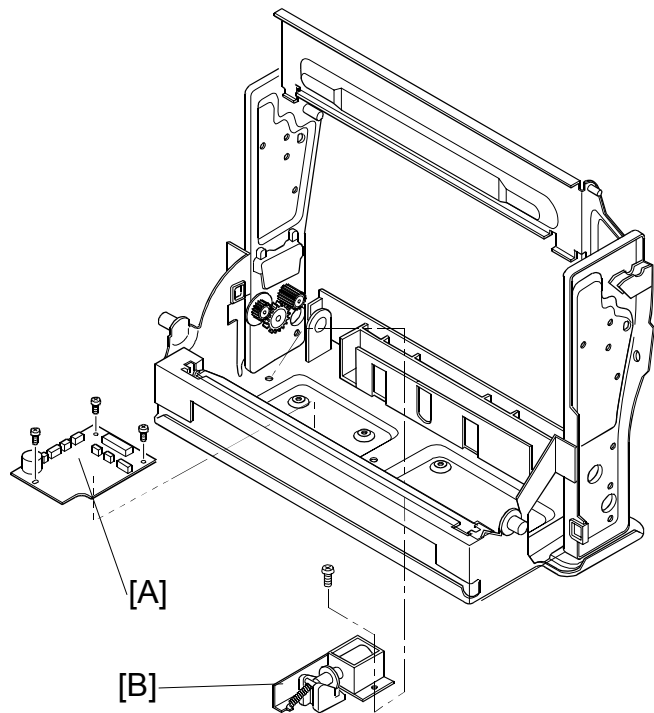

G657R518.WMF

1.6 SENSORS AND SWITCHES

1.6.1 INTERLOCK SWITCHES (D-SW1, D-SW2)

1. Right Side Cover Low. (☛ 1.1.1)
2. Interlock switches [A, B] (☛ x 1, connector x 1)
 - A: Interlock Switch to detect when the Top Unit is open.
 - B: Interlock Switch to detect when the Cover Low is open.

NOTE: After replacing an interlock switch, confirm that it operates normally by opening and closing the Right Cover Low.

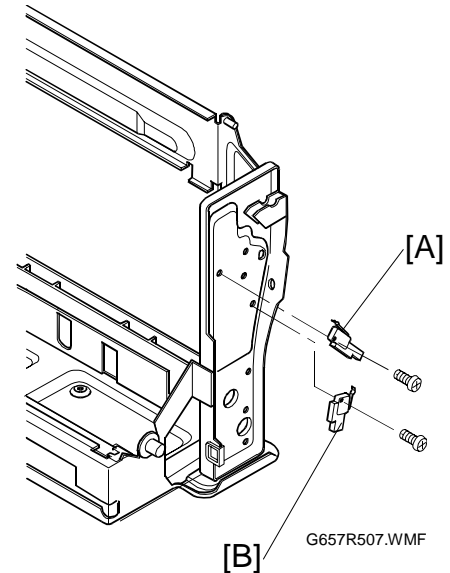

1.6.2 INTERLOCK SWITCH (D-SW3, D-SW4)

1. Left Side Cover Low. (☛ 1.1.2)
2. Interlock switches [A, B] (☛ x 1, connector x 1).
 - A: Interlock Switch to detect when the Top Unit is open.
 - B: Interlock Switch to detect when the Side Cover Low (B) is open.

NOTE: After replacing an interlock switch, confirm that it operates normally by opening and closing the Right Cover Low.

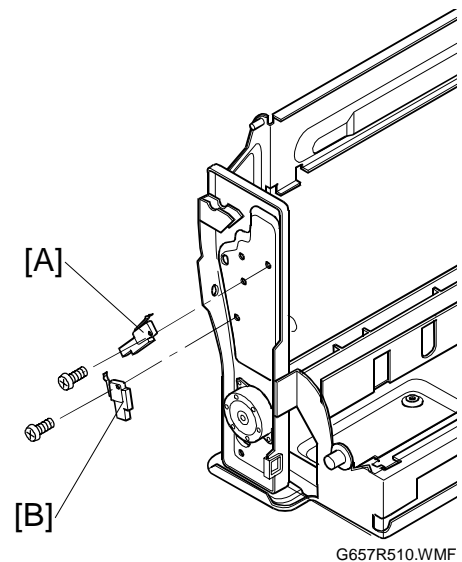

Peripherals

1.6.3 DUPLEX PAPER SENSOR (PT5)

1. Open the Cover Low.
2. Open the Paper Guide RVS IN [A].
3. Sensor Cover [B] (⚙️ x 1).
4. PT5 [C] (connector x 1, feeler x 1), from the Paper Guide RVS Unit.

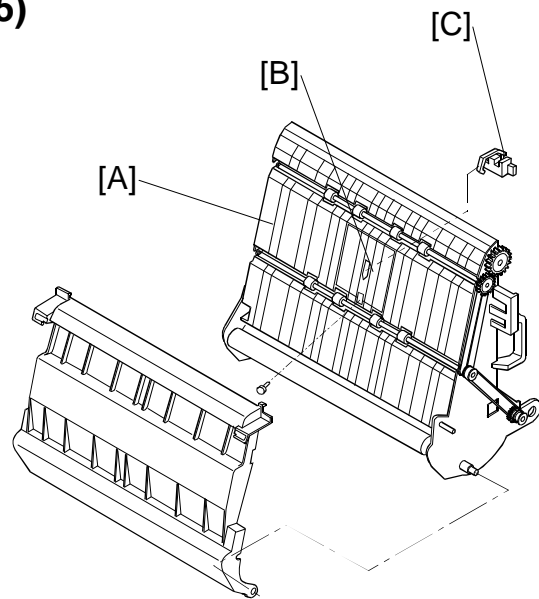

G657R519.WMF

1.6.4 PAPER SENSOR LOW (PT4)

1. Paper Guide Bottom [A]. (☞ 1.1.11)
2. PT4 [B], from the Paper Guide Bottom Assembly [C] (2 hooks, connector x 1).

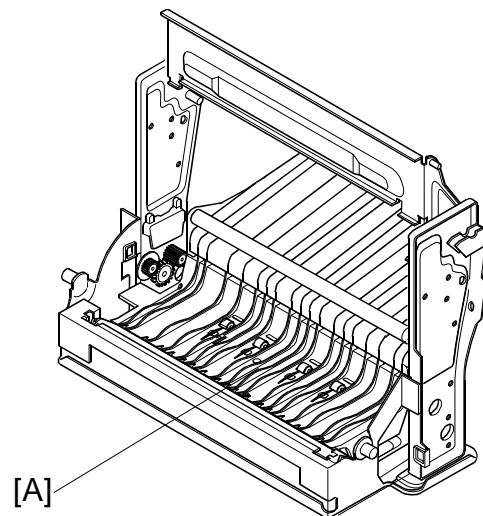

G657R509.WMF

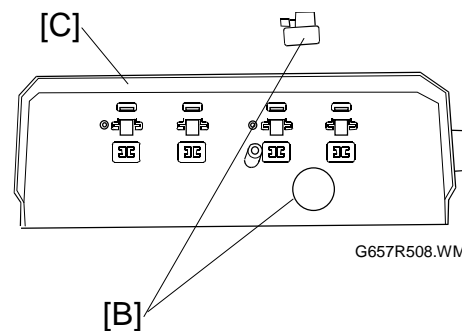

G657R508.WMF

2. DETAILED SECTION DESCRIPTIONS

2.1 INTERNAL STRUCTURE

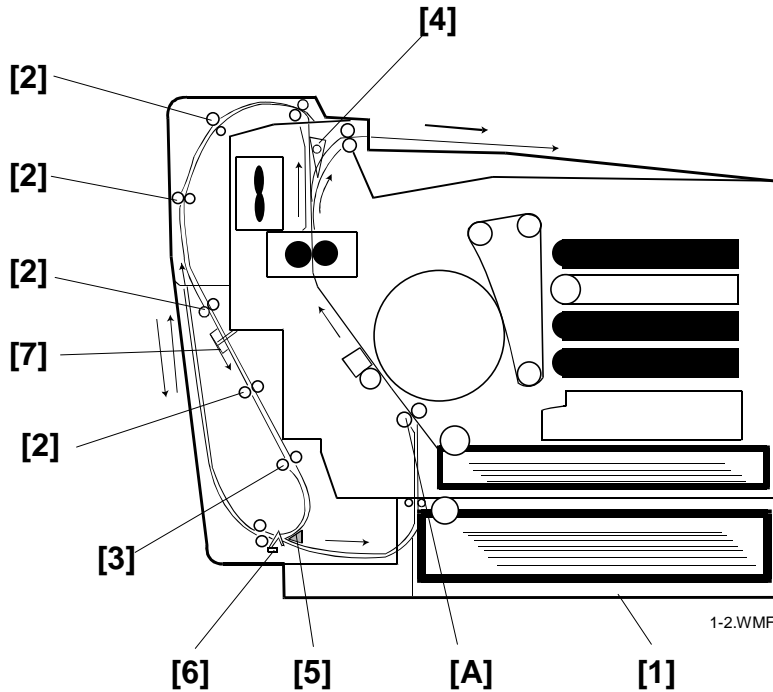

| No. | Name of Part | Function |
|-----|-----------------------|---|
| 1 | LFU Unit | Lower Feed Unit. Duplex Print Paper Feeding Guide. |
| 2 | Transport Rollers | Transportation of paper. |
| 3 | D-Registration Roller | Registration of duplex print paper. |
| 4 | Upper Junction Gate | Switching of paper to the duplex unit. |
| 5 | Lower Junction Gate | Switching of paper from the duplex unit. |
| 6 | D-Sensor (PT4) | Paper Sensor (PT4). |
| 7 | D-Sensor (PT5) | Paper Sensor (PT5). |

Peripherals

2.2 PAPER FEED PATH FOR DUPLEX PRINTING

2.2.1 FEED PATH FOR PRINTING THE REAR SIDE (B FACE)

1. After the image for the B face is formed on the transfer drum, paper is fed from the paper cassette, aligned by the registration roller [A], and fed to the transfer unit for transferring the image onto the B face.
2. For duplex printing, the upper junction gate [4] (in the paper exit unit) guides paper fed from the fusing unit into the upper part of the duplex unit.
3. Then, this paper is fed into the lower unit (the paper guide RVS unit) by the transport rollers [2] and the paper guide (UF).
4. The paper is detected by the paper sensor (PT5) [7] and aligned by the D-registration roller [3]. Then it is guided by the lower junction gate [5] into the paper guide RVS unit.

2.2.2 FEED PATH FOR PRINTING THE FRONT SIDE (A FACE)

1. When the image for the A face has been formed on the transfer drum, the printed paper is fed backwards out of the RVS unit.
2. The lower junction gate [5] is switched, and the paper goes through the bottom guide and is detected by the paper sensor (PT4) [6]. Then, it goes through the paper guide of the lower feeder unit (LFU) [1], and back up to the paper feed path (registration roller in the main body).
3. After being aligned by the registration roller [A], the paper is fed to the transfer unit and the image is transferred to the A face.
4. The paper goes through the fusing unit, and is fed out to the top cover by switching the upper junction gate [4] in the paper exit unit.

2.3 DUPLEX PRINT MODES

There are three duplex print modes that you can select either at the operation panel or with the driver.

2.3.1 DUP-1 MODE

This is standard speed mode.

It is available for single, 2, 3, or 4 colour printing.

Only one sheet of paper is fed at a time.

Operation sequence: ① B → ① A → ② B → ② A

First, the print is made on the rear side (B face) of the paper, and the paper is fed into the duplex unit. Then, the paper is fed from the duplex unit to the paper feed path in the main body of the printer, then the print is made on the front side (A face) of the paper.

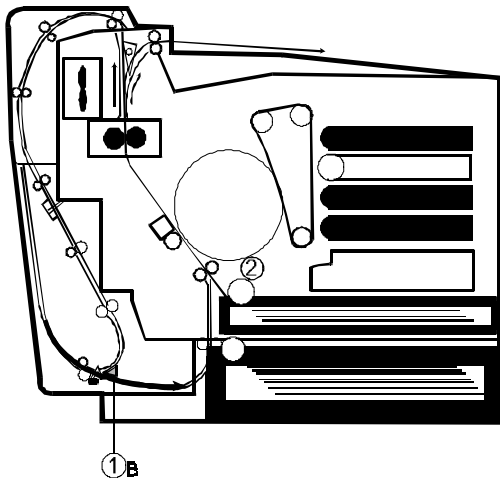

15A.WMF

On the diagrams:
 1B – Sheet 1 with only the B side printed
 1AB – Sheet 1 with both A and B sides printed

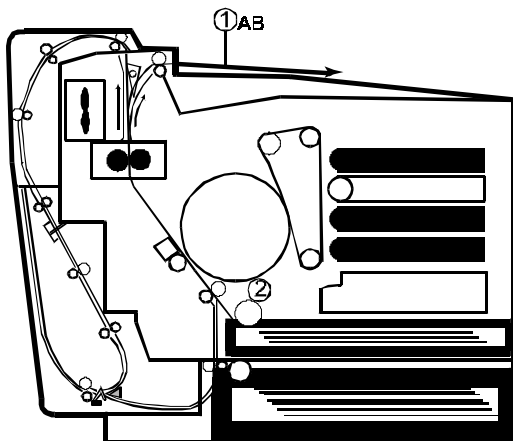

15D.WMF

2.3.2 DUP-2 MODE

This is medium speed mode.

It is available for single, 2, 3, or full color printing.

Two sheets of paper are fed at a time.

Operation sequence: ① B → ② B → ① A → ① A

First, the rear sides (B faces) of two sheets are printed, and these sheets are fed to the duplex unit. Then, they are fed back into the paper feed path in the printer main body and the front sides (A faces) of the two sheets are printed.

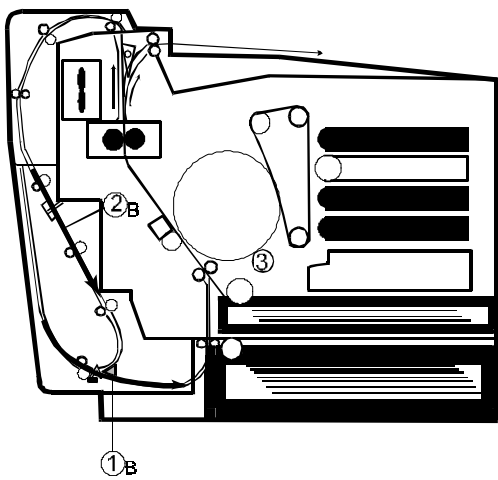

15B.WMF

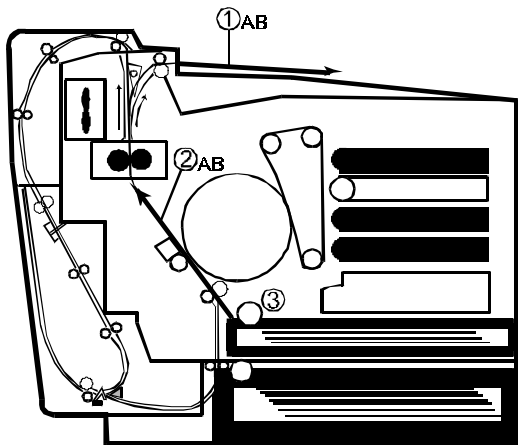

15E.WMF

2.3.3 DUP-3 MODE

This is high speed mode.

It is available for single color printing only.

Three sheets of paper are in the paper feed path at one time.

Operation sequence: ① B → ② B → ③ B → ① A → ④ B → ② A → ⑤ B → ③ A
→ ⑥ B →

1. First, the rear sides (B faces) of the first three sheets are printed.
2. Then, the A face of the first sheet is printed.
3. The second and third sheets are still on their way back towards the paper feed path inside the printer, so the machine next prints the B face of the fourth sheet.
4. Then, the A face of the second sheet is printed.
5. Then, the B face of the fifth sheet is printed.
6. Then, the A face of the third sheet is printed.
7. Then, the B face of the fifth sheet is printed, and so on.

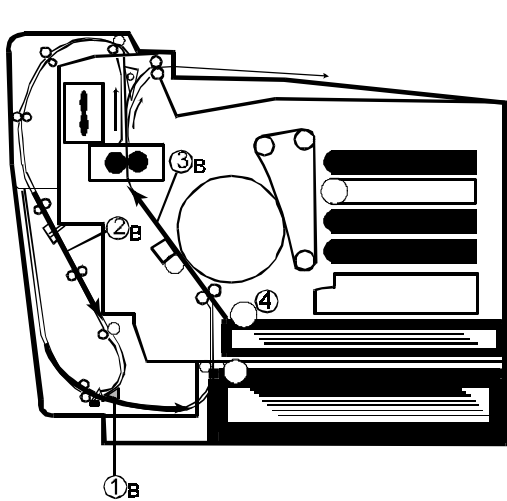

15C.WMF

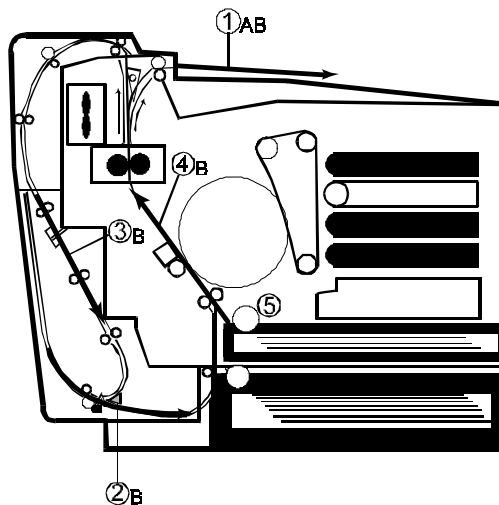

15F.WMF